

# Geometry Semester 1 Exam Review

1. Look at the figure below. Draw the next three tiles.

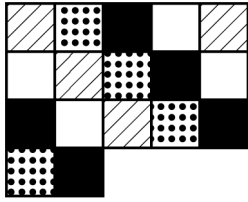

2. How many dots will be in the seventh figure?

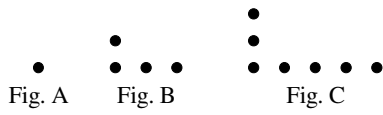

3. If the pattern indicated below continues, what will be the total number of cubes in the 5th stage of the pattern?

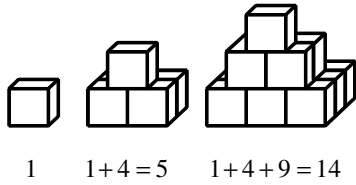

- [A] 6                                      [B] 55                                      [C] 45                                      [D] 36

4. Which of the following points are not coplanar?

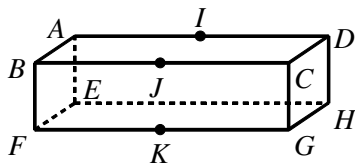

- [A] A, D, H, E                      [B] A, E, F, B                      [C] A, B, C, G                      [D] E, F, G, H

5. Name three points that are collinear.

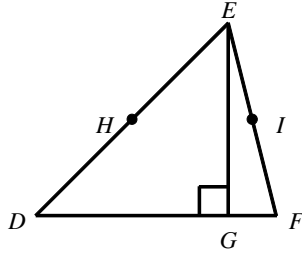

- [A]  $E, H, G$       [B]  $F, I, H$       [C]  $E, F, I$       [D]  $D, E, G$

6. If  $BC = 8$  and  $AC = 27$ , find  $AB$ .      [A] 19    [B] 1    [C] 8    [D] 35

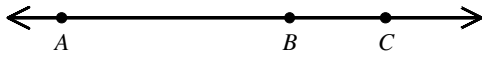

7. If  $m\angle GOI = 42^\circ$  and  $m\angle HOI = 22^\circ$ , then what is the measure of  $\angle GOH$ ?

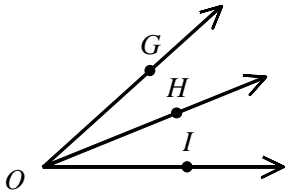

- [A]  $25^\circ$       [B]  $22^\circ$       [C]  $17^\circ$       [D]  $20^\circ$

8.  $M$  is the midpoint of  $\overline{PQ}$ ,  $N$  is the midpoint of  $\overline{MQ}$ , and  $L$  is the midpoint of  $\overline{MN}$ . If  $PQ = 48$ , identify the correct sketch and find  $LQ$ .

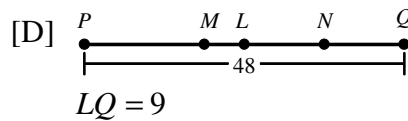
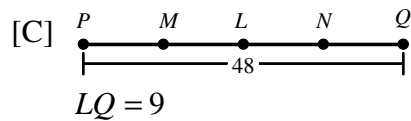
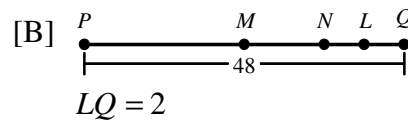
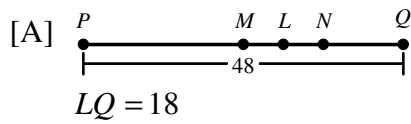

9. Find the coordinates of the midpoint of a segment with the pair of endpoints.  
 $(-1, 1), (3, 5)$

[A]  $(-2, -2)$       [B]  $(-2, -2)$       [C]  $(1, 3)$       [D]  $(0, 4)$

10. Find the midpoint of  $\overline{FG}$ .

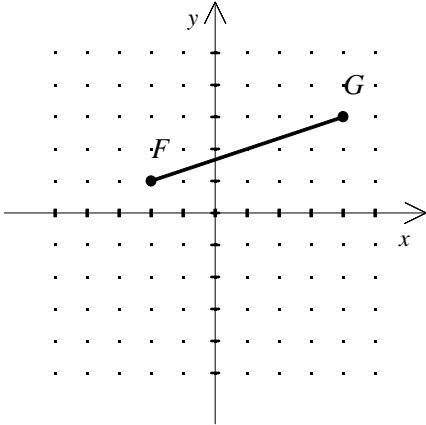

[A]  $(1, 2)$       [B]  $(-1, -2)$       [C]  $(-2, -1)$       [D]  $(2, 1)$

11.  $\overrightarrow{SQ}$  bisects  $\angle RST$ . Find the measure of  $\angle RST$  if  $m\angle RSQ = 25^\circ$ .

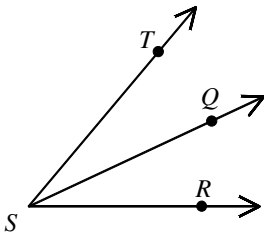

[A]  $100^\circ$       [B]  $25^\circ$       [C]  $50^\circ$       [D]  $40^\circ$

12. If  $\overrightarrow{AD}$  bisects  $\angle BAC$  and  $m\angle BAC = 44^\circ$ , then  $m\angle DAC = \underline{\quad? \quad}$ .

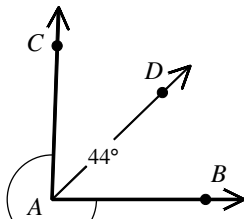

[A]  $88^\circ$       [B]  $46^\circ$       [C]  $22^\circ$       [D]  $44^\circ$

13. Name two supplementary angles that are *not* congruent.

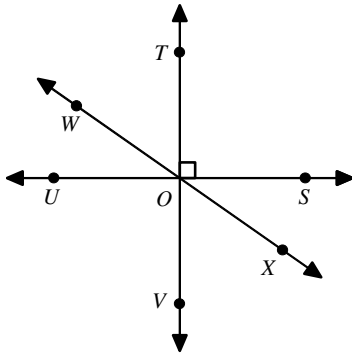

[A]  $\angle VOS$  and  $\angle SOT$

[B]  $\angle SOX$  and  $\angle TOW$

[C]  $\angle WOV$  and  $\angle VOX$

[D]  $\angle WOU$  and  $\angle SOX$

14. Find the measure of a complement of an angle that measures  $20^\circ$ .

[A]  $160^\circ$

[B]  $110^\circ$

[C]  $70^\circ$

[D]  $200^\circ$

15. Determine whether the angles are *complementary*, *supplementary*, or *neither*.

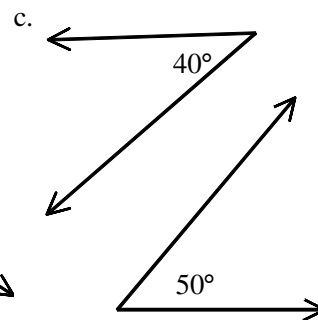
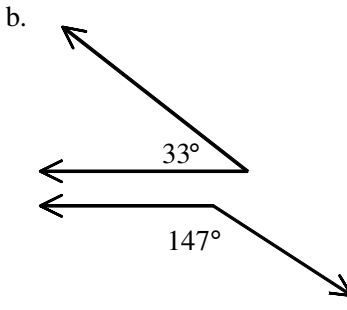
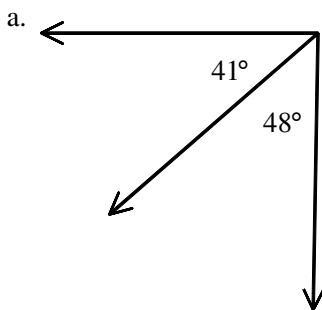

16. Find the measure of a supplement of  $\angle AOC$ .

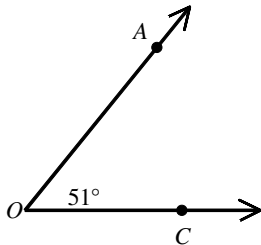

[A]  $78^\circ$

[B]  $102^\circ$

[C]  $129^\circ$

[D]  $39^\circ$

17. Determine which best describes lines  $g$  and  $h$ .

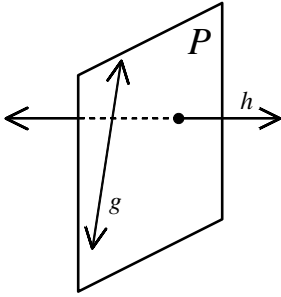

- [A] perpendicular    [B] parallel    [C] skew    [D] none of these

18. Name a pair of parallel planes.

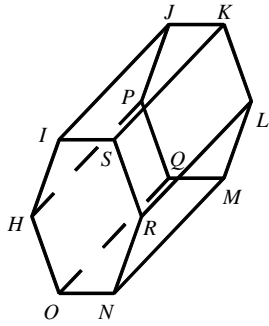

- [A]  $HIS$  and  $RLK$     [B]  $IJK$  and  $OQM$     [C]  $RNO$  and  $RNM$     [D]  $IJK$  and  $RNM$

19. Identify the pair of lines that appear to be parallel.

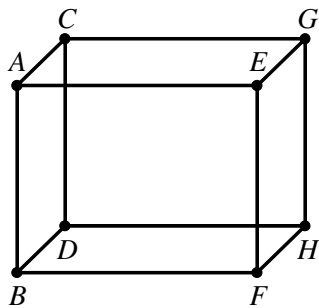

- [A]  $\overleftrightarrow{CD}$  and  $\overleftrightarrow{BD}$     [B]  $\overleftrightarrow{HD}$  and  $\overleftrightarrow{EG}$     [C]  $\overleftrightarrow{AB}$  and  $\overleftrightarrow{EF}$     [D]  $\overleftrightarrow{AE}$  and  $\overleftrightarrow{FH}$

20. Find the value of  $x$ .

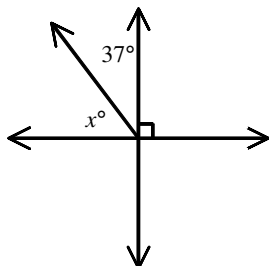

[A] 37

[B] 127

[C] 53

[D] 143

21. What is the relationship between  $\angle 5$  and  $\angle 9$ ?

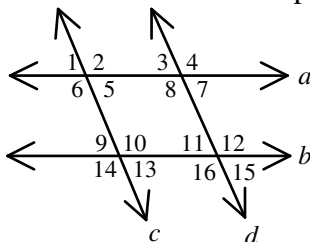

[A] same-side interior angles

[B] alternate interior angles

[C] corresponding angles

[D] none of these

22. Which of the following statements is true?

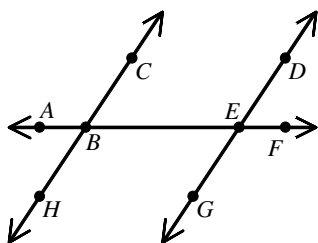

[A]  $\angle ABH$  and  $\angle BEG$  are same-side interior angles.

[B]  $\angle ABH$  and  $\angle BEG$  are alternate exterior angles.

[C]  $\angle BED$  and  $\angle EBH$  are alternate exterior angles.

[D]  $\angle FEG$  and  $\angle EBH$  are corresponding angles.

23. If two parallel lines are cut by a transversal, then corresponding angles are     ? .

[A] complementary

[B] supplementary

[C] acute

[D] congruent

24. In the figure shown,  $m\angle ABC = 149^\circ$ . Which of the following statements is false?

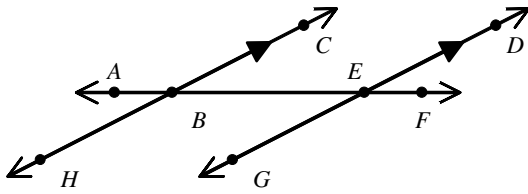

- [A]  $\angle ABH$  and  $\angle AEG$  are corresponding angles.    [B]  $m\angle GEF = 31^\circ$   
 [C]  $m\angle DEF = 31^\circ$     [D]  $\angle HBF$  and  $\angle AED$  are alternate interior angles.

25. What is the measure of  $\angle CFR$ ?

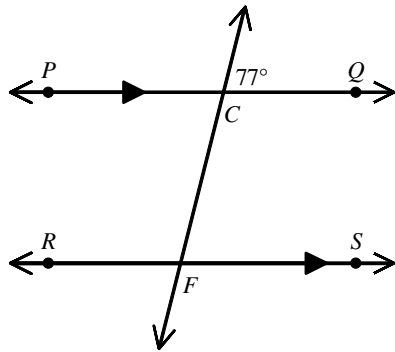

- [A]  $103^\circ$     [B]  $113^\circ$     [C]  $13^\circ$     [D]  $77^\circ$

26. Find  $m\angle 1$  in the figure below.

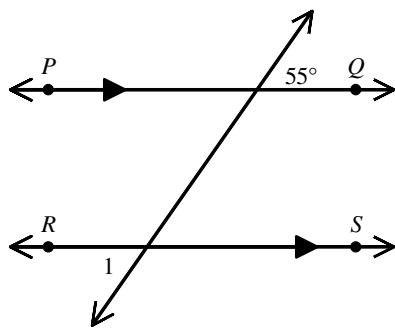

- [A]  $125^\circ$     [B]  $115^\circ$     [C]  $35^\circ$     [D]  $55^\circ$

27. Write the converse of the statement.  
 If it is a digit, then it is a whole number.

28. Find values of  $a$  and  $b$  so that  $l$  and  $m$  are parallel. The diagram is not to scale.

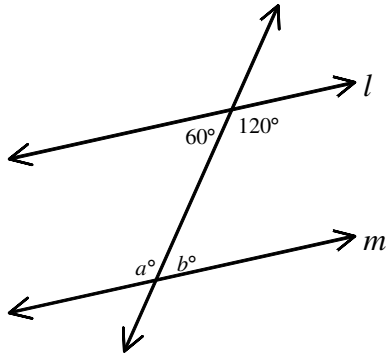

[A]  $a = 120, b = 60$

[B]  $a = 60, b = 60$

[C]  $a = 60, b = 120$

[D]  $a = 120, b = 120$

29. Classify the triangle with the most specific name.

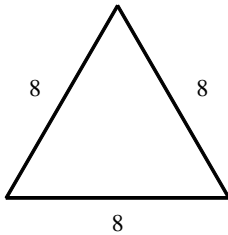

[A] isosceles

[B] scalene

[C] equilateral

[D] none of these

30. Decide whether a triangle could have the given angle measures. Explain your reasoning.  
 $14^\circ, 36^\circ, 130^\circ$

[A] Yes, the sum is  $180^\circ$ .

[B] Yes, the sum is less than  $180^\circ$ .

[C] No, the sum is  $180^\circ$ .

[D] No, the sum is greater than  $180^\circ$ .

31. In  $\triangle ABC$ ,  $m\angle A = 70^\circ$  and  $m\angle C = 52^\circ$ . Find  $m\angle B$ .

[A]  $160^\circ$

[B]  $142^\circ$

[C]  $122^\circ$

[D]  $58^\circ$

32. Find the value of  $x$ . The diagram is not to scale.

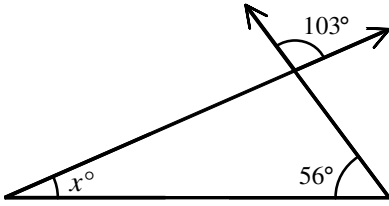

[A] 34

[B] 47

[C] 77

[D] 21

33. Find the values of  $x$  and  $y$ . The diagram is not to scale.

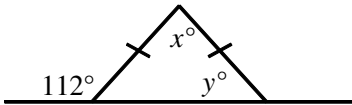

[A]  $x = 44$ ;  $y = 68$

[B]  $x = 44$ ;  $y = 112$

[C]  $x = 68$ ;  $y = 48$

[D]  $x = 68$ ;  $y = 112$

34. A median of a triangle is a segment from \_\_\_?\_\_\_ to the midpoint of the opposite side.

[A] the center of the triangle    [B] a vertex    [C] a side    [D] an angle bisector

35. Which equation can be used to solve for  $x$ ? What is the value of  $x$ ?

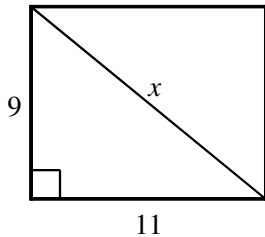

[A]  $9^2 + 11^2 = x^2$ ; 14.21

[B]  $11^2 + x^2 = 9^2$ ; 6.32

[C]  $9^2 + x^2 = 11^2$ ; 6.32

[D]  $9^2 + 11^2 = x^2$ ; 202

36. Name a median for  $\triangle ABC$ .

[A]  $\overline{CE}$

[B]  $\overline{BD}$

[C]  $\overline{AF}$

[D]  $\overline{AD}$

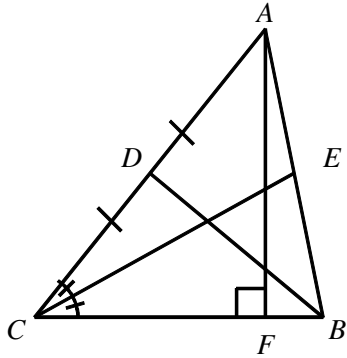

37. The two triangles are congruent. Find the missing side lengths and the missing angle measures.

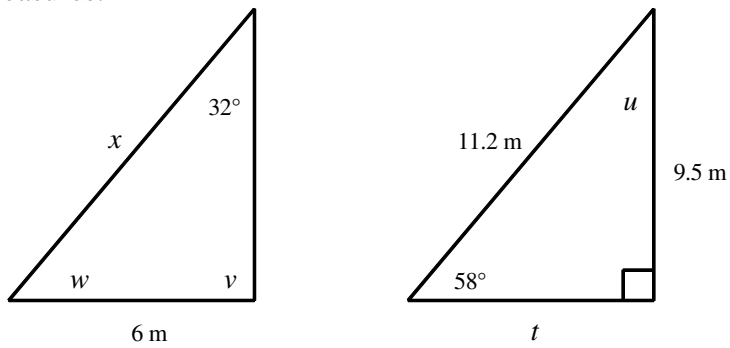

[A]  $t = 6\text{ m}$ ;  $u = 32^\circ$ ;  $v = 90^\circ$ ;  $w = 58^\circ$ ;  $x = 6\text{ m}$

[B]  $t = 6\text{ m}$ ;  $u = 32^\circ$ ;  $v = 90^\circ$ ;  $w = 58^\circ$ ;  $x = 11.2\text{ m}$

[C]  $t = 6\text{ m}$ ;  $u = 32^\circ$ ;  $v = 58^\circ$ ;  $w = 90^\circ$ ;  $x = 6\text{ m}$

[D]  $t = 9.5\text{ m}$ ;  $u = 32^\circ$ ;  $v = 90^\circ$ ;  $w = 58^\circ$ ;  $x = 11.2\text{ m}$

38. Decide whether enough information is given to show that the triangles are congruent. If there is enough information, state the congruence postulate you would use.

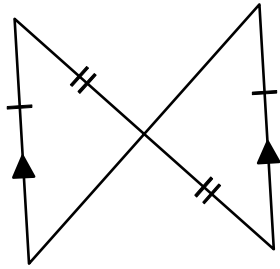

- [A] Yes, SSA      [B] Yes, SAS      [C] Yes, SSS      [D] Not enough information

39. Tell which postulate or theorem you would use to show that the triangles are congruent.

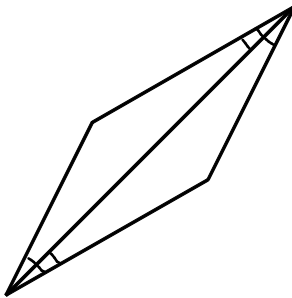

- [A] SAS      [B] ASA      [C] SSS      [D] AAS

40. Given:  $\overleftrightarrow{DE}$  is the perpendicular bisector of  $\overline{IK}$ . Which statement is true?

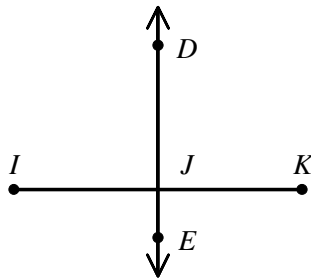

- [A]  $\overline{DE} \perp \overline{IK}$       [B]  $E$  is the midpoint of  $\overline{IK}$ .  
 [C]  $EK = DK$       [D]  $\angle IDK$  is a right angle.

41. Use the diagram to find  $PQ$ .

[A] 6

[B] 12

[C] 14

[D] 24

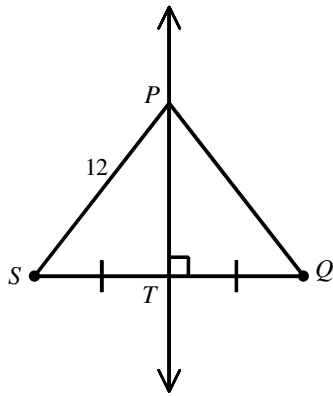

42. Use the information in the diagram to solve for  $x$ . The diagram is not to scale.

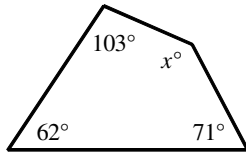

[A] 79

[B] 34

[C] 124

[D] 214

43. In parallelogram  $ABCD$ , find  $BC$ .

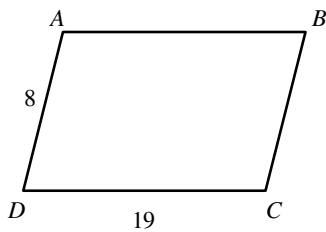

[A] 27

[B] 19

[C] 11

[D] 8

44. For the parallelogram below, if  $m\angle 1 = m\angle 3 = (3.5x)^\circ$ ,  $m\angle 2 = (5x - 160)^\circ$ , and  $m\angle 4 = x^\circ$ , find the value of  $x$ . The diagram is not to scale.



- [A] 80                      [B] 100                      [C] 50                      [D] 40
45. Complete the statement.  
If both pairs of opposite sides of a quadrilateral are    ?   , then the quadrilateral is a parallelogram.
- [A] congruent              [B] adjacent              [C] perpendicular              [D] none of these
46. If  $m\angle C = m\angle A = 110^\circ$ , find  $m\angle B$  so that quadrilateral  $ABCD$  is a parallelogram.

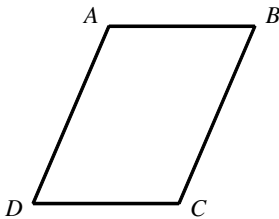

- [A]  $70^\circ$                       [B]  $20^\circ$                       [C]  $110^\circ$                       [D]  $160^\circ$
47. Find the measure. rhombus  $WXYZ$                       [A] 14              [B] 3.5              [C] 28              [D] 7

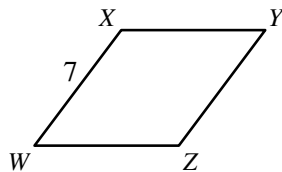

$YZ = \underline{\quad? \quad}$

48. Find the value of  $x$ . rhombus  $WXYZ$

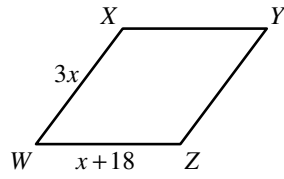

[A] 9

[B] 18

[C] 27

[D] 3

49. For the pair of similar polygons, find the missing side.

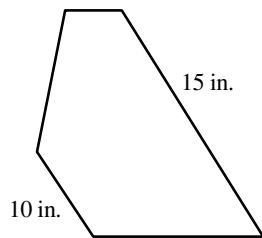
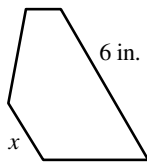

[A] 1 in.

[B] 4 in.

[C] 3 in.

[D] 2 in.

50.  $\triangle PQR \sim \triangle STU$ .

What is the measure of  $\angle U$ ?

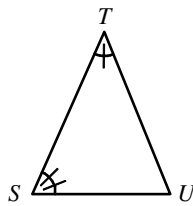
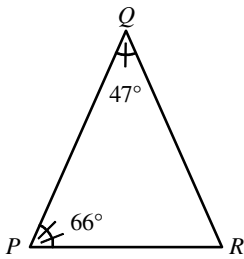

[A]  $67^\circ$

[B]  $113^\circ$

[C]  $33.5^\circ$

[D]  $247^\circ$

51. Use similar triangles to find  $x$ .

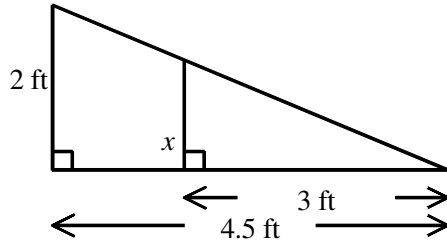

52. The triangles below are similar. Find the value of  $x$ . The diagram is not to scale.

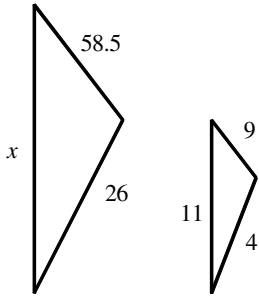

[A] 31.8

[B] 78

[C] 71.5

[D] 1.7

53. Use the information in the diagram to determine the height of the tree.

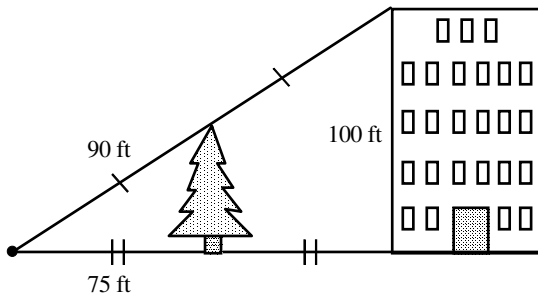

[A] 37.5 ft

[B] 45 ft

[C] 50 ft

[D] 165 ft

54. Identify the convex polygon.

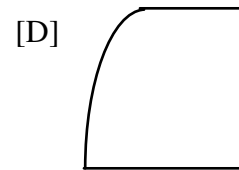
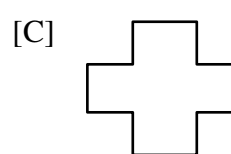
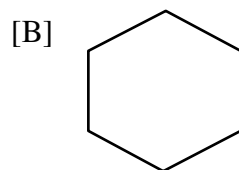
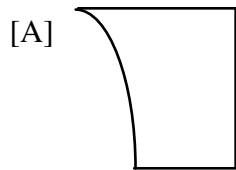



60. What is the area of the rectangle below?

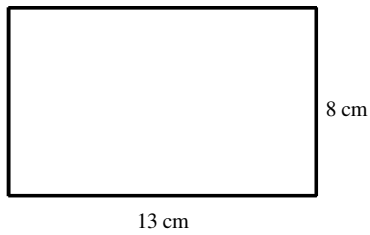

- [A]  $208 \text{ cm}^2$       [B]  $104 \text{ cm}^2$       [C]  $42 \text{ cm}^2$       [D]  $21 \text{ cm}^2$

61. The perimeter of a square is 72 centimeters. Find the area of the square.

- [A]  $325 \text{ cm}^2$       [B]  $18 \text{ cm}^2$       [C]  $17 \text{ cm}^2$       [D]  $324 \text{ cm}^2$

62. Find the measure of a supplement of  $\angle AOC$ .

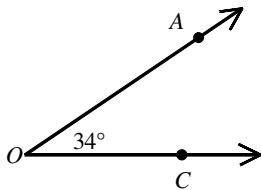

- [A]  $56^\circ$       [B]  $68^\circ$       [C]  $146^\circ$       [D]  $152^\circ$

63. Line segments  $AC$  and  $BD$  intersect at  $E$ .  $m\angle AED = 134^\circ$ . What is the measure of  $\angle BEC$ ?

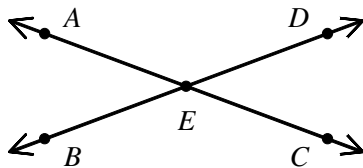

- [A]  $124^\circ$       [B]  $134^\circ$       [C]  $56^\circ$       [D]  $46^\circ$

64. Classify the triangle.

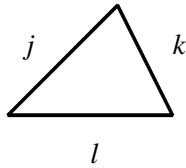

- [A] acute                      [B] obtuse                      [C] right                      [D] equiangular

65. How long is the road that goes directly from Briarton to Carlsville?

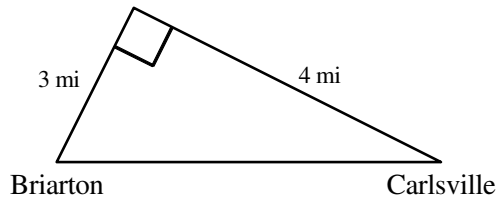

- [A] 8 mi                      [B] 6 mi                      [C] 3 mi                      [D] 5 mi

66. If the hypothesis of a true if-then statement is true, then the \_\_\_?\_\_\_ is also true.

- [A] detachment              [B] hypothesis              [C] syllogism              [D] conclusion

67. Rewrite the statement as an if-then statement. Every equilateral triangle has three congruent sides.

- [A] If a figure is an equilateral triangle, then it has three congruent sides.  
[B] A figure has three congruent sides if and only if it is an equilateral triangle.  
[C] If a figure has three congruent sides, then it is an equilateral triangle.  
[D] A figure is an equilateral triangle if and only if it has three congruent sides.

68. Identify the hypothesis and conclusion of the if-then statement. If the doorbell rings, then the dog barks.

69. A line perpendicular to a plane is a line that intersects a plane in a point and that is perpendicular to every \_\_\_?\_\_\_ in the plane that intersects it.

- [A] line                      [B] point                      [C] angle                      [D] plane

70. Given:  $\overleftrightarrow{AB}$  is perpendicular to  $\overline{LN}$ . Which statement is true?

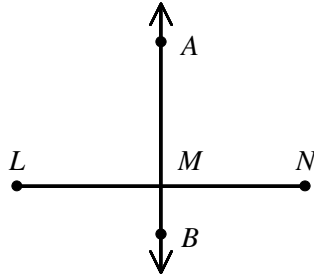

- [A]  $BN = AN$     [B]  $B$  is the midpoint of  $\overline{LN}$ .    [C]  $\angle LAN$  is a right angle.  
 [D]  $\angle AMN, \angle NMB, \angle BML, \angle LMA$  are all right angles.

71. Which of the following statements is true?

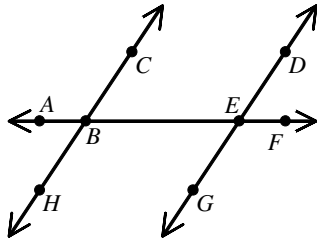

- [A]  $\angle ABH$  and  $\angle BEG$  are corresponding angles.  
 [B]  $\angle CBE$  and  $\angle BED$  are alternate exterior angles.  
 [C]  $\angle CBE$  and  $\angle BED$  are corresponding angles.  
 [D]  $\angle ABH$  and  $\angle DEF$  are corresponding angles.

72. The converse of an if-then statement is the statement formed by switching the \_\_\_?\_\_\_ and the \_\_\_?\_\_\_.

73. Write the converse of the statement.  
 If it is a dime, then it is a coin.

74.  $m\angle 2 = (3x + 104)^\circ$  and  $m\angle 8 = (4x + 41)^\circ$ . Find the value of  $x$  for which  $\overleftrightarrow{AB} \parallel \overleftrightarrow{CD}$ . The diagram is not to scale.

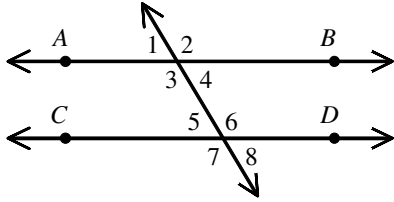

- [A] 3                      [B] 6                      [C] 5                      [D] 4

75. Which drawing is a construction of the line perpendicular to the given line through point  $P$ ?

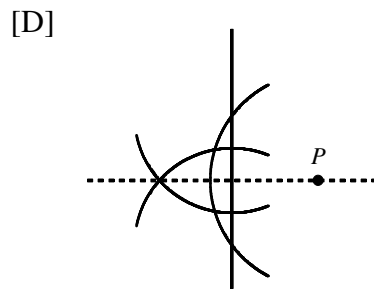
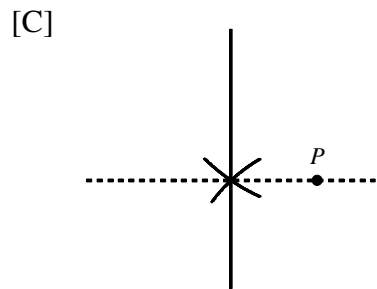
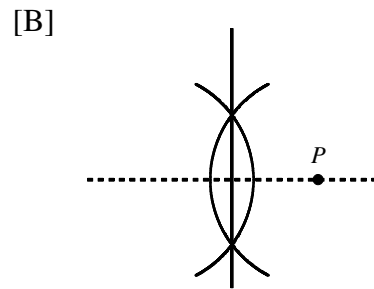
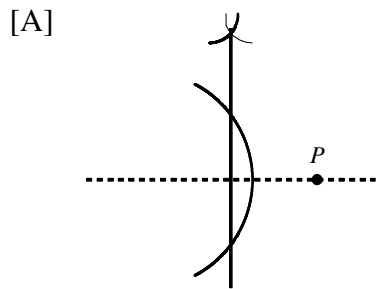
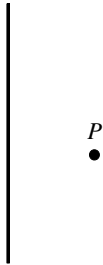

76.

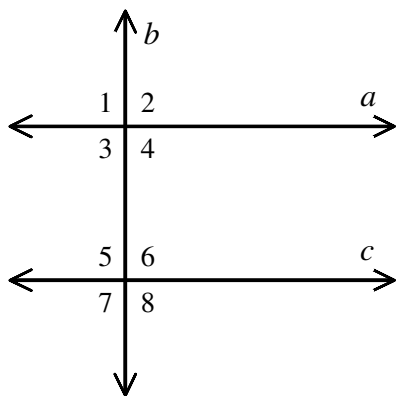

If  $c \perp b$  and  $a \parallel c$ , what is  $m\angle 2$ ?

- [A]  $60^\circ$       [B]  $30^\circ$       [C]  $90^\circ$       [D] not enough information

77. Choose the best phrase to complete the statement.

No sides of \_\_\_?\_\_\_ triangle are the same length.

- [A] a scalene      [B] an equilateral      [C] an isosceles      [D] none of these

78. Classify the triangle in two ways.

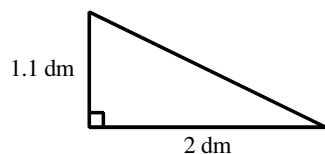

- [A] scalene, obtuse      [B] equilateral, obtuse  
[C] equilateral, acute      [D] scalene, right

79. Find the value of  $x$ . The diagram is not to scale.

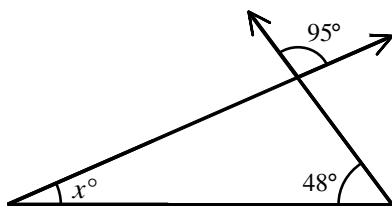

- [A] 47      [B] 85      [C] 37      [D] 42

80. What is the measure of each base angle of an isosceles triangle if its third angle measures 44 degrees and its 2 congruent sides measure 21 units?

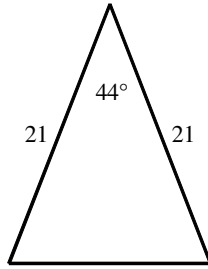

- [A]  $68^\circ$                       [B]  $44^\circ$                       [C]  $46^\circ$                       [D]  $136^\circ$
81. What is the distance between opposite corners of a 3 by 5 inch photograph?
- [A]  $2\sqrt{2}$  in.                      [B]  $\sqrt{34}$  in.                      [C] 34 in.                      [D] 8 in.
82. Find the length of  $\overline{AB}$  given that  $\overline{DB}$  is a median of the triangle and  $BC$  is 9.

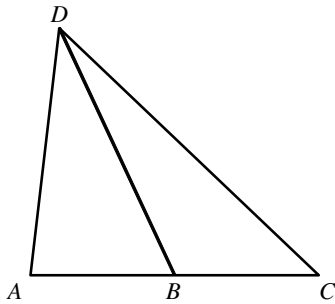

- [A] 18                      [B] 9                      [C] 8                      [D] 4.5

83. If  $\triangle KLM \cong \triangle ONM$ , which of the following is true?

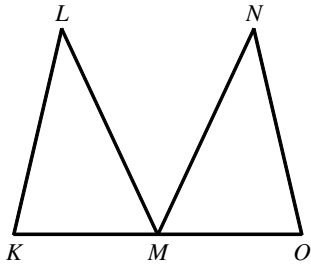

- [A]  $\angle K \cong \angle M$ ,  $\angle N \cong \angle O$ ,  $\angle KML \cong \angle OMN$  ;  
 $\overline{KM} \cong \overline{OM}$ ,  $\overline{KL} \cong \overline{ON}$ ,  $\overline{LM} \cong \overline{NM}$
- [B]  $\angle K \cong \angle O$ ,  $\angle L \cong \angle N$ ,  $\angle KML \cong \angle OMN$  ;  
 $\overline{KL} \cong \overline{ON}$ ,  $\overline{KM} \cong \overline{OM}$ ,  $\overline{LM} \cong \overline{NM}$
- [C]  $\angle K \cong \angle M$ ,  $\angle N \cong \angle O$ ,  $\angle KML \cong \angle OMN$  ;  
 $\overline{KM} \cong \overline{ON}$ ,  $\overline{KL} \cong \overline{OM}$ ,  $\overline{LM} \cong \overline{NM}$
- [D]  $\angle K \cong \angle O$ ,  $\angle L \cong \angle N$ ,  $\angle KML \cong \angle OMN$  ;  
 $\overline{KL} \cong \overline{ON}$ ,  $\overline{KM} \cong \overline{NM}$ ,  $\overline{LM} \cong \overline{OM}$

84. The two triangles are congruent. Find the missing side lengths and the missing angle measures.

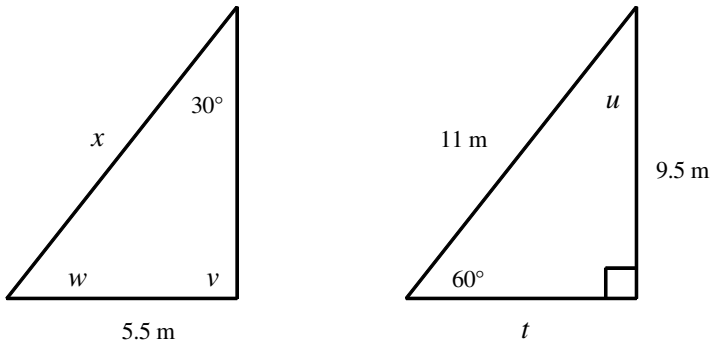

- [A]  $t = 5.5$  m;  $u = 30^\circ$ ;  $v = 60^\circ$ ;  $w = 90^\circ$ ;  $x = 5.5$  m
- [B]  $t = 5.5$  m;  $u = 30^\circ$ ;  $v = 90^\circ$ ;  $w = 60^\circ$ ;  $x = 5.5$  m
- [C]  $t = 9.5$  m;  $u = 30^\circ$ ;  $v = 90^\circ$ ;  $w = 60^\circ$ ;  $x = 11$  m
- [D]  $t = 5.5$  m;  $u = 30^\circ$ ;  $v = 90^\circ$ ;  $w = 60^\circ$ ;  $x = 11$  m

85.  $\angle BAC \cong$  ?

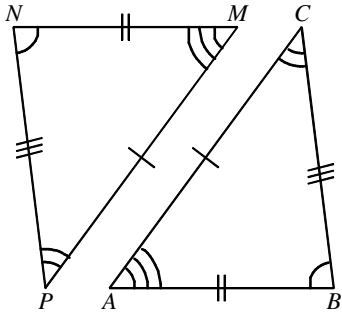

- [A]  $\angle NPM$       [B]  $\angle NMP$       [C]  $\angle MNP$       [D]  $\angle PNM$

86. Fill in the missing statement to complete the two-column proof:

Given:  $\overline{CB} \cong \overline{CD}$ ;  $\angle BCA \cong \angle DCA$

Prove:  $\triangle ABC \cong \triangle ADC$

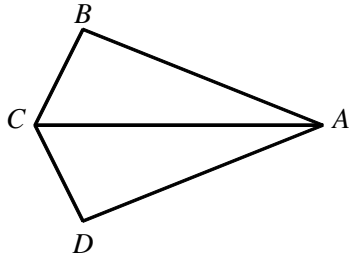

- |  |                                     |
|--|-------------------------------------|
| 1. ?                                   | 1. Given                            |
| 2. $\overline{AC} \cong \overline{AC}$ | 2. Reflexive Property of Congruence |
| 3. $\triangle ABC \cong \triangle ADC$ | 3. SAS                              |

[A]  $\overline{CB} \cong \overline{CD}$ ,  $\angle BCA \cong \angle DCA$

[B]  $\overline{AC} \cong \overline{CA}$ ,  $\angle ACD \cong \angle ACB$

[C]  $\overline{BA} \cong \overline{DA}$ ,  $\angle BAC \cong \angle DAC$

[D] none of these

87. Decide whether enough information is given to show that the triangles are congruent. If there is enough information, state the congruence postulate you would use.

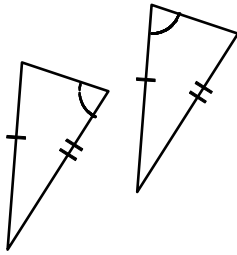

- [A] Yes, SAS      [B] Yes, SSS      [C] Yes, SSA      [D] Not enough information

88. Determine what information you would need to know in order to use the SAS Congruence Postulate to show that the triangles are congruent.

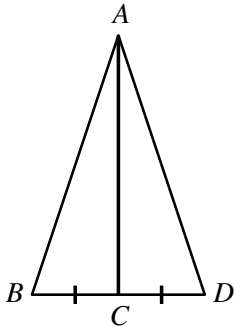

- [A]  $\overline{AB} \cong \overline{AD}$       [B]  $\angle BAD \cong \angle CDA$       [C]  $\overline{AC} \perp \overline{BD}$       [D]  $\angle BAC \cong \angle DAC$

89. Tell whether the side is *included* or *not included* between the given angles.

$\overline{PN}$  is   ?   by  $\angle P$  and  $\angle N$ .

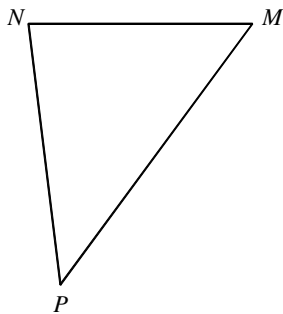



94. Determine which triangles are congruent by AAS under the given conditions.

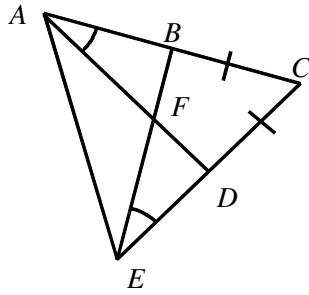

[A]  $\triangle ABE \cong \triangle EDA$

[B]  $\triangle ABE \cong \triangle CBE$

[C]  $\triangle ABF \cong \triangle EDF$

[D]  $\triangle ADC \cong \triangle EBC$

95. Supply the missing reasons to complete the proof.

Given:  $\angle A \cong \angle D$  and  $\overline{AC} \cong \overline{DC}$

Prove:  $\overline{BC} \cong \overline{EC}$

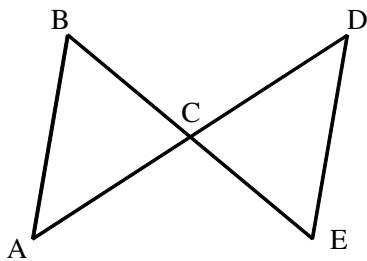

Statements	Reasons
1. $\angle A \cong \angle D$ $\overline{AC} \cong \overline{DC}$	1. Given
2. $\angle BCA \cong \angle ECD$	2. Vertical angles are congruent.
3. $\triangle BCA \cong \triangle ECD$	3. <u>?</u>
4. $\overline{BC} \cong \overline{EC}$	4. <u>?</u>

[A] ASA; Corr. parts of cong.  $\Delta$ s are cong.

[B] SSS; Corr. parts of cong.  $\Delta$ s are cong.

[C] SAS; Corr. parts of cong.  $\Delta$ s are cong.

[D] ASA; Substitution property of equality



100. Find the value of  $x$ .

[A] 23

[B] 80

[C] 103

[D] 86

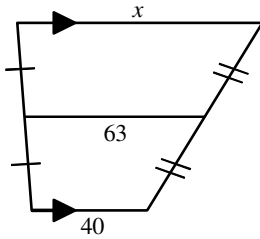

101. Find the values of  $a$  and  $b$ .

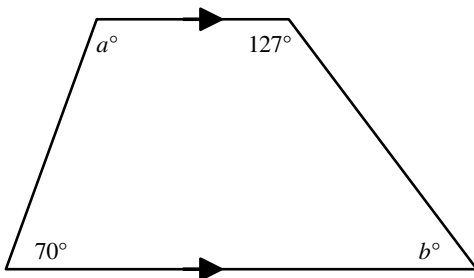

[A]  $a = 110, b = 37$

[B]  $a = 110, b = 53$

[C]  $a = 70, b = 53$

[D]  $a = 70, b = 37$

102. Classify the figure in as many ways as possible.

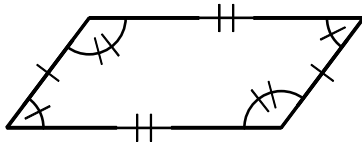

[A] trapezoid, quadrilateral

[B] quadrilateral, parallelogram, rhombus

[C] quadrilateral, parallelogram

[D] rectangle, quadrilateral

103. Which statement is true?

[A] Every rectangle is a rhombus.

[B] Every square is a rectangle.

[C] Every quadrilateral is a rectangle.

[D] Every rectangle is a square.

104. In the diagram,  $ST: TU$  is  $1:3$  and  $SU = 20$ . Find  $ST$  and  $TU$ .

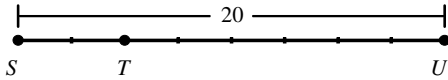

- [A]  $ST = 15$ ;  $TU = 5$                       [B]  $ST = 1$ ;  $TU = 3$   
 [C]  $ST = 10$ ;  $TU = 30$                       [D]  $ST = 5$ ;  $TU = 15$
105. A map has a scale of  $1 \text{ cm}:18 \text{ km}$ . If two cities are 4 centimeters apart on the map, what is the actual distance between the two cities?
- [A] 72 km                      [B] 4.5 km                      [C] 0.2 km                      [D] 720 km
106. Find the ratio of the length to the width of the rectangle. Then simplify the ratio.

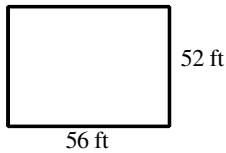

- [A]  $\frac{14}{13}$                       [B]  $\frac{4}{52}$                       [C]  $\frac{4}{13}$                       [D]  $\frac{56}{52}$
107. Find the ratio of the perimeter of the larger rectangle to the perimeter of the smaller rectangle.

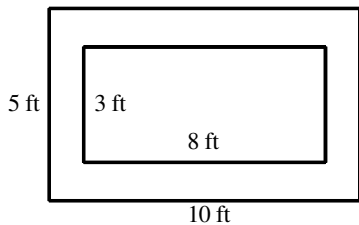

- [A]  $\frac{5}{3}$                       [B]  $\frac{5}{4}$                       [C]  $\frac{15}{11}$                       [D]  $\frac{11}{15}$

108. Write a similarity statement for the triangles and find the value of the variable.

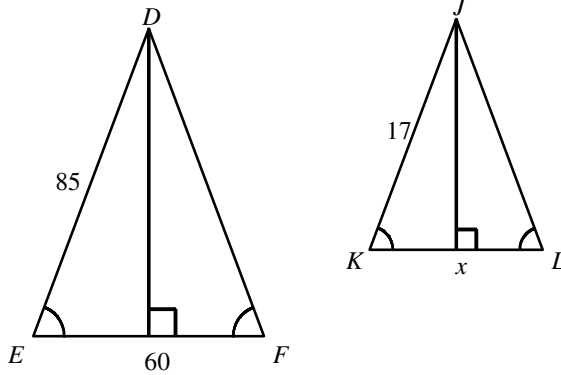

[A]  $\triangle DEF \sim \triangle JLK$ ,  $x = 25$

[B]  $\triangle DEF \sim \triangle JKL$ ,  $x = 25$

[C]  $\triangle DEF \sim \triangle JKL$ ,  $x = 12$

[D] The triangles are not similar.

109. Determine whether the two triangles are similar. If they are similar, write a similarity statement.

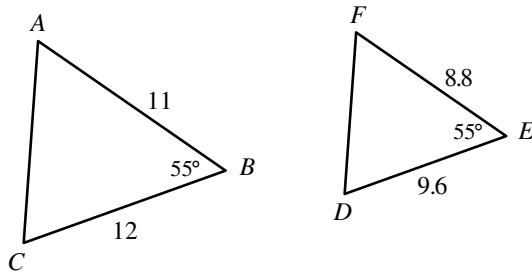

[A] similar;  $\triangle ABC \sim \triangle FED$

[B] similar;  $\triangle ABC \sim \triangle FDE$

[C] similar;  $\triangle ABC \sim \triangle EDF$

[D] not similar

110. In  $\triangle JLN$ , if  $\overline{KM} \parallel \overline{JN}$ , then \_\_\_?\_\_\_.

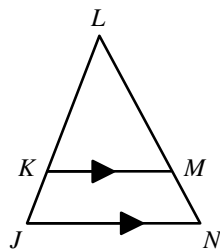

[A]  $\frac{LK}{KJ} = \frac{LM}{MN}$

[B]  $\frac{LK}{LM} = \frac{MN}{KJ}$

[C]  $\frac{LM}{KJ} = \frac{LK}{MN}$

[D]  $\frac{LM}{LK} = \frac{KJ}{MN}$

111. Find the value of each variable. The diagram is not to scale.

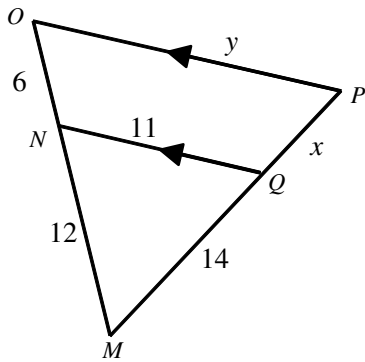

[A]  $x = 7; y = 16.5$

[B]  $x = 16.5; y = 7$

[C]  $x = 9; y = 16.5$

[D]  $x = 14; y = 11$

112. Find the value of  $x$ .

- [A] 150    [B] 60    [C] 120    [D] 50

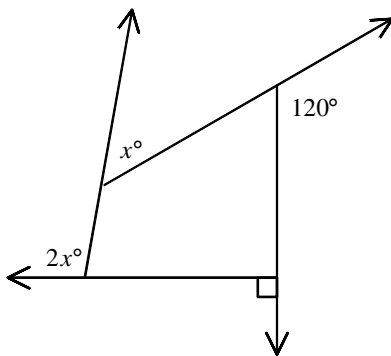

113. Find the area of the trapezoid. The diagram is not to scale.

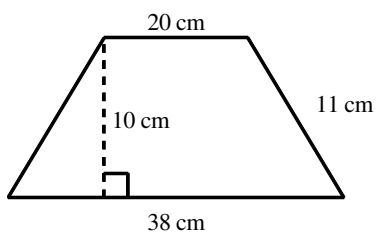

[A]  $290 \text{ cm}^2$

[B]  $580 \text{ cm}^2$

[C]  $638 \text{ cm}^2$

[D]  $319 \text{ cm}^2$

114. The sum of the measures of nine exterior angles of a decagon is  $277^\circ$ . What is the measure of the tenth exterior angle?